

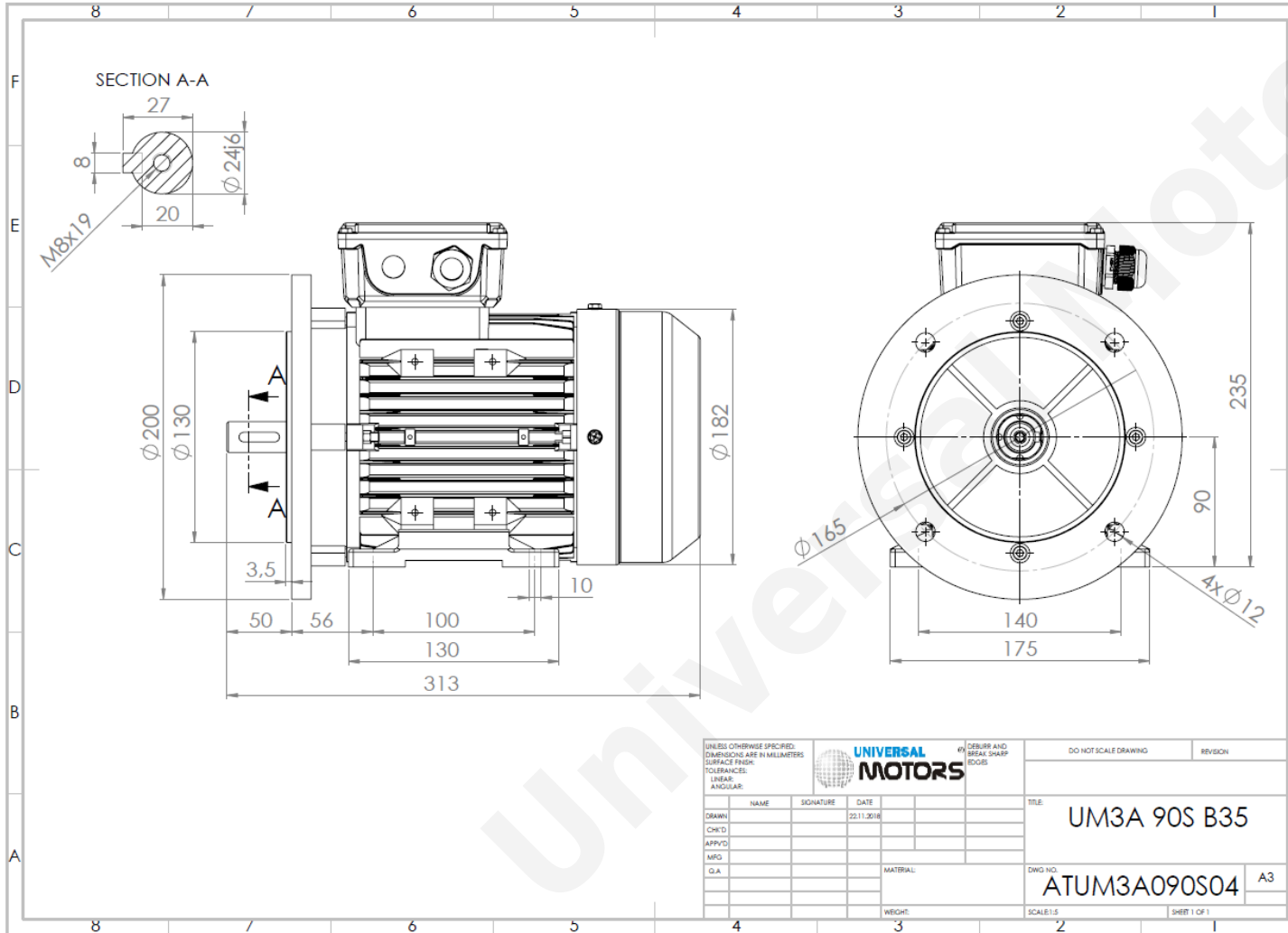

TECHNICAL DATA

Three Phase Electric Motors - Aluminum Frame
 PE31 90S-2
 1.5 kW / 2 Cv
 2855 RPM



Motor type:	PE31 90S-2
Output:	1.5 kW / 2 Cv
Speed (min ⁻¹):	2855 RPM
Frequency:	50 Hz
Voltage:	400 V
Current:	3.1 A
Power factor (Cos Ø):	0.84
Poles:	2
Insulation class:	F
Temperature rise Class:	B
Efficiency 50%:	82.1 %
Efficiency 75%:	82.9 %
Efficiency 100%:	84.2 %
Torque:	5.02 N.m
Tstarting/Tnominal:	2.3
Istarting/Inominal:	7.6
Tmaximum/Tnominal:	2.3
Noise:	78 Db(A)
Weight:	14 Kg
Bearing DE:	6205 2Z C3
Bearing NDE:	6205 2Z C3

Regime - S1

Altitude - 1000m

Environment Temperature - 40°C

CONTACTS:

UNIVERSAL MOTORS Tel: +351 252 299 080
 Rua de São Brás,745 Fax: +351 252 299 089
 4480-782 VILA DO CONDE Mail: geral@universalmotors.pt

* References applied only in the UK